

ECONOBOTICS REALITY LEVELS IN THE ENTERPRISES EVOLUTION ANALYSIS

Ioana ARMAŞ*

***Abstract.** In the context of the econobotic framework for the enterprises development introduced and defined in [1] the present paper extends the concept and the attached context by identifying: the reality levels corresponding to the econobotic environment and the relations between them; the 3 – dimensional space in which the enterprise’s behaviour and evolution will be considered.*

Thus, the concept of econobotics will be developed towards an holistic and heterogeneous theoretical model based upon multiple reality levels and specific parameters. In this context, for the 3 – dimensional space definition will be determined a ‘wrapping up’ method of several parameters in order to establish the corresponding coordinates in the competitiveness / econobotic space.

The obtained econobotic environment is a complex representation of the socio – economic – technical modern world and represents the foundation for further developments with applications in management.

***Keywords:** econobotics, competitiveness, enterprises evolution, econobotic space, reality levels.*

1. Introduction

The enterprise’s competitiveness represents a complex problem that must be solved in a dynamic and unpredictable environment. From this point of view, the enterprise will be considered as an heterogeneous system able to perform its functions in attaining its goals by: perceiving its internal and external environments, processing data and information, deciding regarding the necessary internal and external actions, and performing these actions accordingly.

Thus, results that the enterprise represents an econobotic system (see [1]) such that, the enterprise will be analyzed and designed for competitiveness in an econobotic framework. The competitiveness

* Faculty of Exact and Engineering Sciences, Department of Automatics and Applied Informatics, Hyperion University, Bucharest, Romania ioanaarm@yahoo.com.

problems will be defined and detailed in the *TSE* (Technical – Social – Economical) space, as introduced in [1], as econobotic problems.

In order to develop models for the competitiveness oriented design and analysis of the enterprise as an econobotic system, two main aspects should be considered:

- a) the reality levels of the econobotic environment;
- b) the *TSE* space definition considering the above determined reality levels.

Based on **a** and **b** the model for analyzing and representing in the design process the enterprise as an econobotic system may be further developed.

2. Econobotics reality levels

The human, social and economic developments together with the technical and technological ones are deployed in the corresponding environments governed by specific laws that determine the reality levels.

Econobotics, viewed as a global, heterogeneous management model, must consider the specific reality levels as (fig. 1):

1. ***The physical reality level*** governed by the physical laws of nature or of the natural environment, with the under micro-, micro- and macro- dimensional levels.
2. ***The biological reality level*** governed by specific, objective laws of life as growth, birth, reproduction, mutation, agency etc.
3. ***The human reality level*** governed by its material and conceptual laws of life, goals, psychology, moral etc., virtual representations, creativity and agency, reasoning, consciousness etc.
4. ***The social reality level*** governed by laws regarding the synergistic integration of individuals in a general objectivity of interaction context emerged from individual subjectivities.
5. ***The technical reality level*** governed by the physical laws of nature, human creativity, and necessities and desires of life and well-being.
6. ***The economic reality level*** governed by the subjective views regarding property, profit, trade etc. and their material representations and models by money, monetary context and finances.

3. The construction of the *TSE* space

For the competitiveness representation as the interface between the enterprise's internal and external environments the following dimensions of a 3 –D space, the *TSE* space, where established in [1]: technical (*T*), social (*S*), and economic (*E*).

Each dimension will be represented by an unique axis, and integrates the corresponding set of specific and determinant parameters, such that the *TSE* space will be an heterogeneous one as in figure 2.

Thus, each dimension will represent a reality level (see figure 1), such that the *TSE* space will be a transdisciplinary one for which the global laws will integrate the corresponding specific ones of each level of reality.

The construction of such an heterogeneous and transdisciplinary space will consider a technique able to wrap up parameters in an unique dimension, based upon an integration function of weighted elements, as in figure 3.

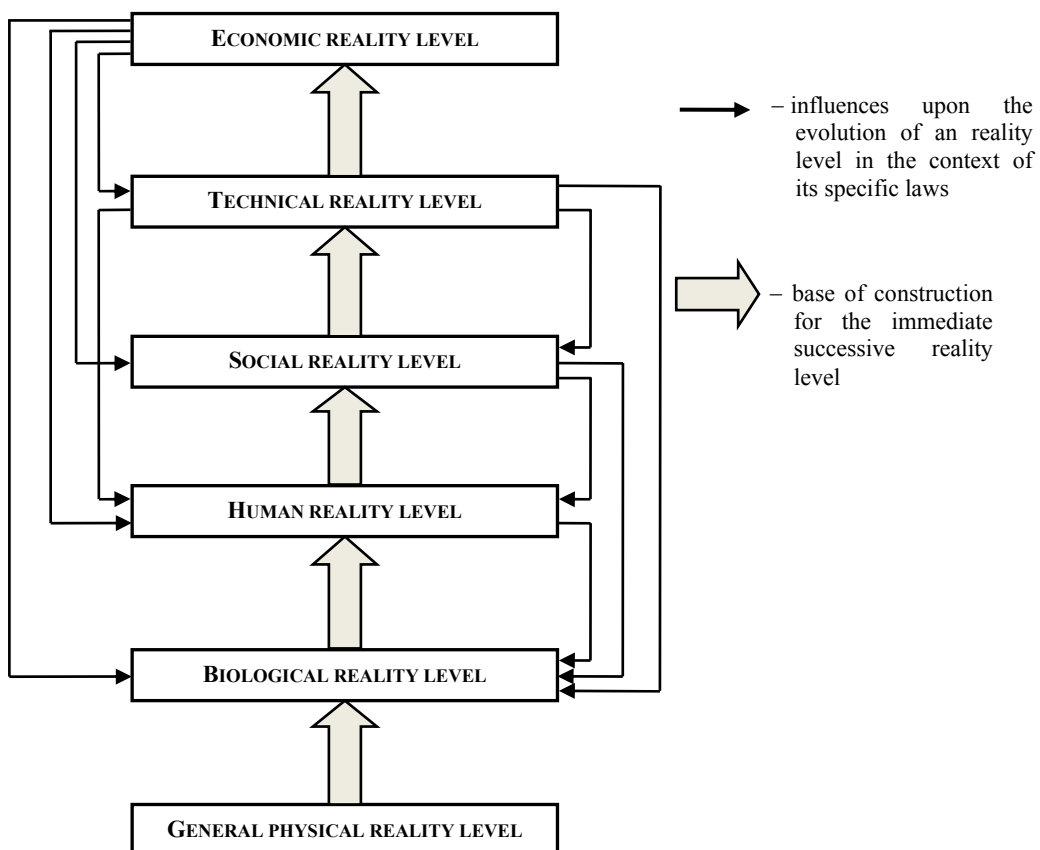

Figure 1. The econobotics reality levels and the corresponding relations.

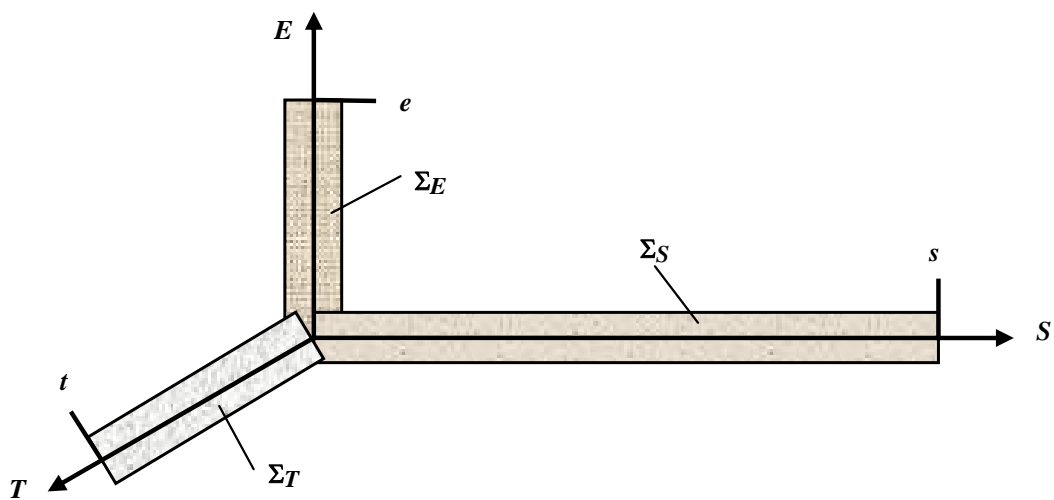

Figure 2. The TSE space as the result of specific parameters integration.
T – the technical dimension; *S* – the social dimension; *E* – the economic dimension;
 $\Sigma_T, \Sigma_S, \Sigma_E$ – the sets of technical, social and respectively economic parameters.

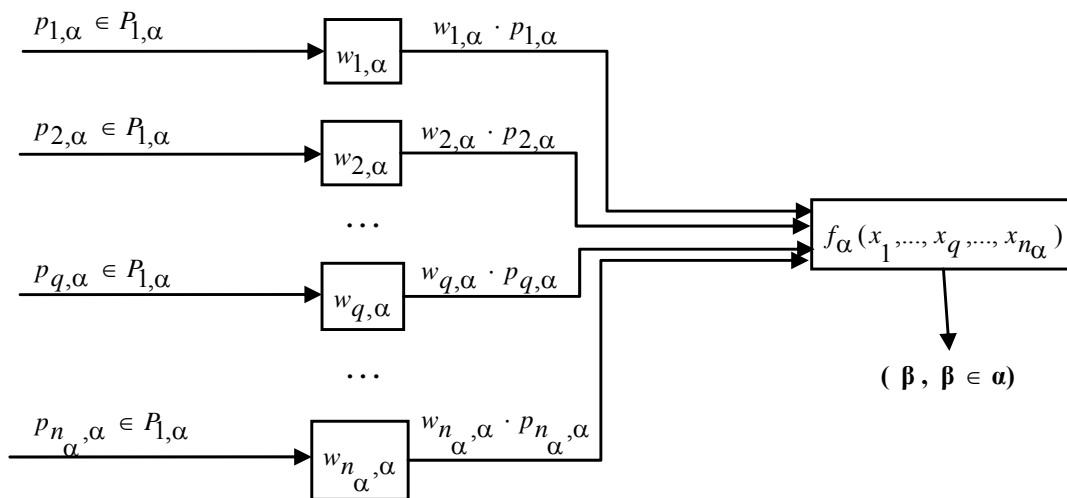

Figure 3. The wrapping up principle in obtaining the α dimensions ($\alpha = T, S, E$) of the TSE space and their corresponding coordinates $\beta = t, s, e$ by weighted parameters integration.
 $p_{1,\alpha}, \dots, p_{q,\alpha}, \dots, p_{n_\alpha,\alpha}, \alpha = T, S, E$ – parameters of the α dimension;
 $P_{1,\alpha}, \dots, P_{q,\alpha}, \dots, P_{n_\alpha,\alpha}, \alpha = T, S, E$ – definition sets of the parameters.

In figure 3, for each dimension $\alpha = T, S, E$ to be constructed will be considered the parameters types by their characteristic sets, $P_{q, \alpha}$, $q = \overline{1, n_\alpha}$, $\alpha = T, S, E$, that will determine the dimensional sets as:

$$P_{1, \alpha} \times P_{2, \alpha} \times \dots \times P_{q, \alpha} \times \dots \times P_{n_\alpha, \alpha} \xrightarrow{f_\alpha} \alpha, \quad \alpha = T, S, E, \quad (1)$$

and for the specific values of the parameters, the corresponding global coordinates will be obtained as:

$$\begin{aligned} \beta &= f(w_{1, \alpha} \cdot p_{1, \alpha}, \dots, w_{q, \alpha} \cdot p_{q, \alpha}, \dots, w_{n_\alpha, \alpha} \cdot p_{n_\alpha, \alpha}), \\ (\beta = t, \alpha = T), (\beta = s, \alpha = S), (\beta = e, \alpha = E), \end{aligned} \quad (2)$$

with $w_{1, \alpha} + \dots + w_{q, \alpha} + \dots + w_{n_\alpha, \alpha} = 1$, such that:

$$t = f(w_{1, T} \cdot p_{1, T}, \dots, w_{q, T} \cdot p_{q, T}, \dots, w_{n_T, T} \cdot p_{n_T, T}) \in T, \quad (3a)$$

$$s = f(w_{1, S} \cdot p_{1, S}, \dots, w_{q, S} \cdot p_{q, S}, \dots, w_{n_S, S} \cdot p_{n_S, S}) \in S, \quad (3b)$$

$$e = f(w_{1, E} \cdot p_{1, E}, \dots, w_{q, E} \cdot p_{q, E}, \dots, w_{n_E, E} \cdot p_{n_E, E}) \in E. \quad (3c)$$

If more complex wrapping techniques are needed, then the model of figure 3 may be developed at $N \geq 2$ levels, each level having $r = N, N-1, \dots, 2$ component function and level N only one, thus resulting a $N(N, N-1, \dots, 2, 1)$ wrapping circuit analogues to the neural integration of information.

In figure 4 a $2(2, 1)$ wrapping circuit corresponding to 2 – levels with $(2, 1)$ component functions is represented.

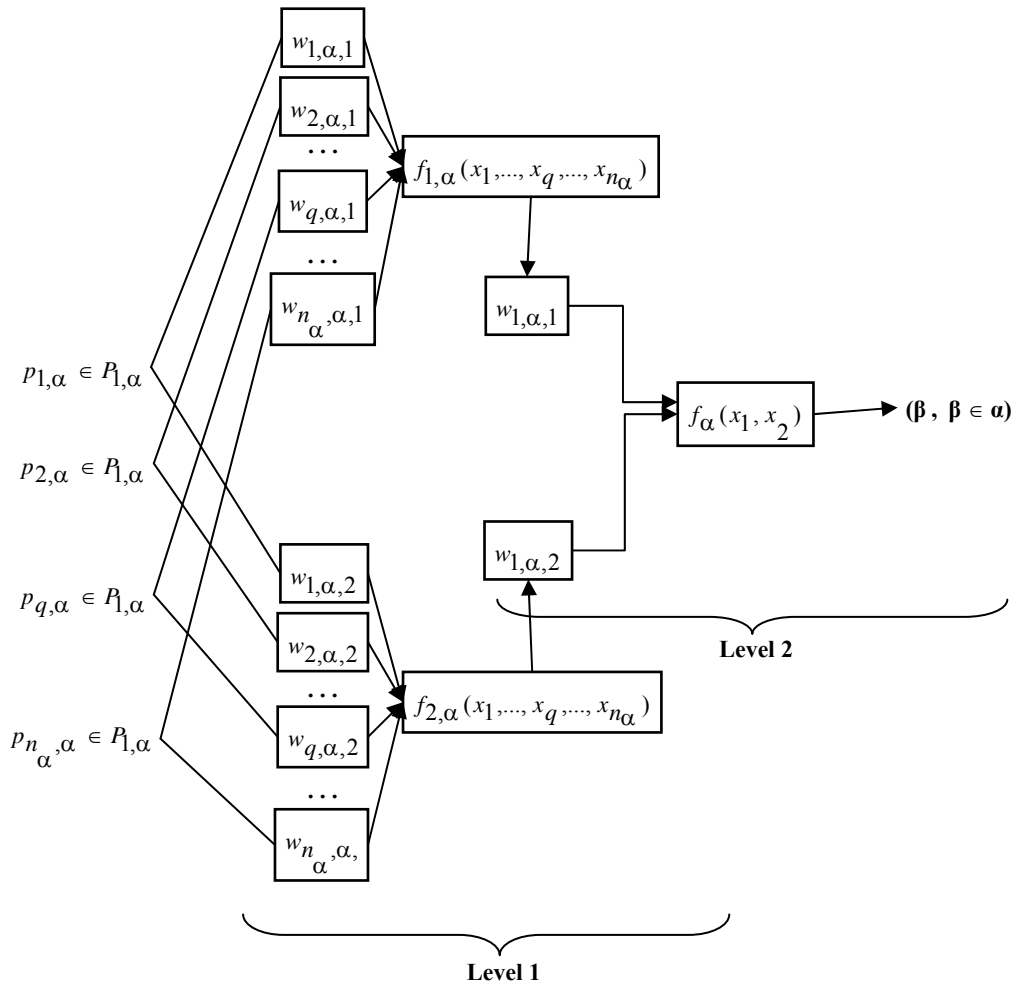

Figure 4. A $2(2,1)$ wrapping up model for the $\alpha = T, S, E$ dimension of the econobotic space.

Considering the architectures presented in figures 3 and 4, results that this wrapping up techniques are similar to the artificial neural network (ANN) context, such that more complex models may be developed by considering different ANN structures.

4. Synergistic parameters integration in *TSE* space construction

Let be $p_{1,\alpha}, p_{2,\alpha}, \dots, p_{q,\alpha}, \dots, p_{n_\alpha,\alpha}, \alpha = T, S, E$ the parameters of the α dimension of the econobotic space represented in a global definition set,

P_α , with the attached operation set, Q_α , evaluated at $V_{1,\alpha}, V_{2,\alpha}, \dots, V_{q,\alpha}, \dots, V_{n_\alpha,\alpha}$, $\alpha = T, S, E$, and assuming K_α to be the knowledge set attached to P_α , then the synergistic parameters integration is the matrix $(\beta, V_\alpha)_{P_\alpha, T_\alpha}^T$, $\beta = t, s, e$ obtained as:

$$\left(\begin{array}{cccc} p_{1,\alpha} & p_{2,\alpha} & \dots & p_{n_\alpha,\alpha} \\ V_{1,\alpha} & V_{2,\alpha} & \dots & V_{n_\alpha,\alpha} \end{array} \right)_{P_\alpha, K_\alpha} \xrightarrow{Q_\alpha} \left(\begin{array}{c} \beta \\ V \end{array} \right)_{P_\alpha, K_\alpha}, \quad (4)$$

where the global parameter β is obtained applying the defined operations, Q_α (see figure 5) according to the relation:

$$(p_{1,\alpha} \ p_{2,\alpha} \ \dots \ p_{n_\alpha,\alpha}) \xrightarrow{Q_\alpha} \beta, \quad (5)$$

and V is the global evaluation as the global meaning corresponding to β determined by the relation:

$$V = \{ \Lambda_{kj,\alpha} = (\varphi_{kj,\alpha}, \psi_{jk,\alpha}) : \varphi_{kj,\alpha} \neq 0, \psi_{jk,\alpha} \neq 0, \forall k \neq j, k, j = \overline{1, n_\alpha}; \\ \varphi_{kj,\alpha} : V_{k,\alpha} | V_{j,\alpha} \xrightarrow{Q_\alpha, K_\alpha} V_{j,\alpha}; \psi_{jk,\alpha} : V_{j,\alpha} | V_{k,\alpha} \xrightarrow{Q_\alpha, K_\alpha} V_{k,\alpha} \}. \quad (6)$$

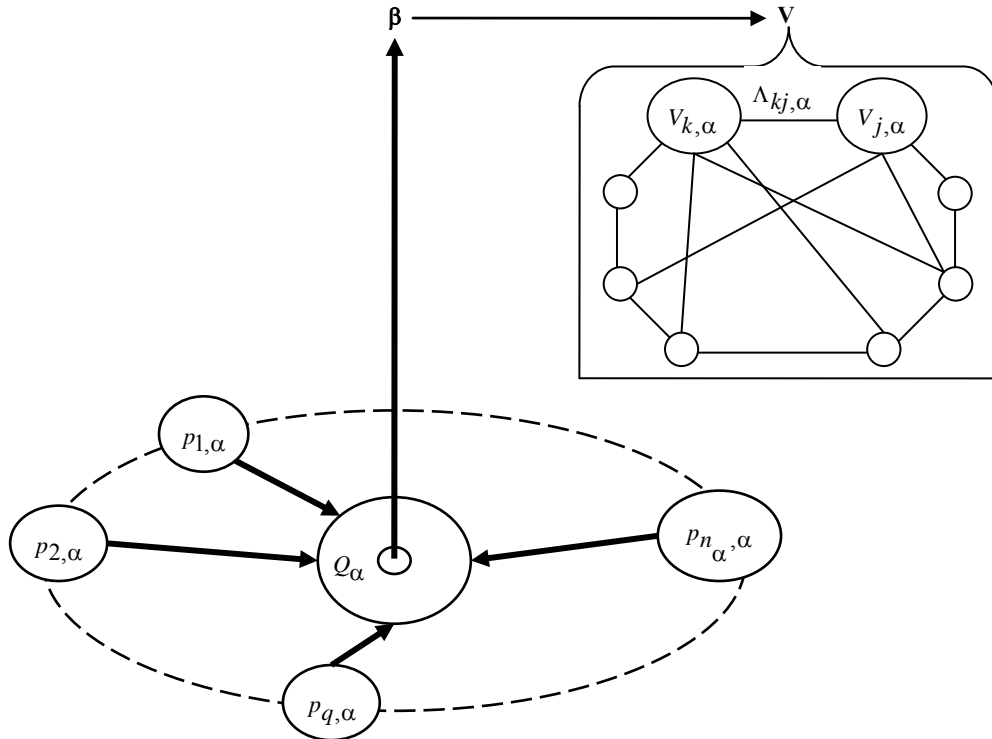

Figure 5. The synergistic parameters integration in the *TSE* space construction.

In relation (6) the functions $\varphi_{kj,\alpha}$ and $\psi_{jk,\alpha}$ define the way in which, for the context of Q_α and K_α , the evaluation $V_{k,\alpha}$ in the presence of $V_{j,\alpha}$ determines the evaluation $V_{j,\alpha}$, and respectively $V_{j,\alpha}$ in the presence of $V_{k,\alpha}$ determines $V_{k,\alpha}$ (see figure 5).

According to the synergistic integration definition developed in [1, 2, 3, 4] the parameters are organised and structured such that every $p_{k,\alpha}, k = \overline{1, n_\alpha}$ is connected by a $\Delta_{kj,\alpha} \in V$ with at least one $p_{j,\alpha}, j \neq k, j = \overline{1, n_\alpha}$.

The operation set, Q_α , may be constituted from mathematical formulas, logical connectors, or other types of operators compatible to P_α .

5. Conclusions

The present paper extends the concept and the theoretical foundations of the *econobotic* field defined and introduced in [1].

Thus, the corresponding integrated reality levels were determined, such that the transdisciplinarity of econobotics resulted as an important consequence of its heterogeneity.

Also, considering that each dimension of the *TSE* space is determined by many parameters, an wrapping up techniques, based upon artificial neural networks, was proposed in order to establish the corresponding coordinates of econobotic systems (e.g. enterprises, organizations etc.).

In this context, a qualitative approach based upon the synergistic integration of parameters and their values was developed in order to analyze and identify through interpretation in a knowledge context the *TSE* coordinates.

REFERENCES

- [1] I. Armas, *Econobotics – A New Framework for the Enterprises Development*, Hyperion International Journal of Econophysics and New Economy 2015, Volume 8, Issue2, pp. 203-303.
- [2] I. Armas, *Intelligent Systems Design in Logic Computational Context* (in Romanian), Editura AGIR, Bucharest, 2013.
- [3] I. Armas, *Design for Mechatronics and Robotics* (in Romanian), Editura AGIR, Bucharest, 2011.
- [4] I. Armas, *Mechatronic Products and Services* (in Romanian), Editura AGIR, Bucharest, 2009.